

Connecting the Valve Wires (Figure 3)

Step 1- Route a multi-wire, direct-burial sprinkler cable from the sprinkler timer to the valves. If the cable run is less than 800', 18 AWG wire is sufficient. For distance from 800' – 2000', 14 AWG wire is recommended.

Step 2- Using wire splice connectors, attach either wire from each valve solenoid to the white cable wire. This wire is designated as the valve "Common Wire." Connect the remaining wire from the solenoid to one of the color-coded wires.

▲ Important: All wire splices must be properly insulated to prevent a short circuit or corrosion from occurring. Installing grease caps or waterproof connectors is recommended.

Step 3- At the timer, connect the control wires from valves to the numbered terminals in the desired operating sequence. Connect the valve common wire to the valve common terminal.

Step 4- Using the timer's manual control feature, test the operation of each valve.

Finishing the Installation (Figure 4)

Step 1- Once valve operation has been successfully tested with the timer, control wires can be buried and a valve box installed.

Manual Operation (Figure 5)

• Manually open the valve by turning the bleed screw counterclockwise 1/2 turn. To close the valve, turn the bleed screw clockwise. **Do not over-tighten!**

Note: The valve may take several seconds to shut off when operated manually.

• To adjust flow, (model 53682 only) turn the flow control handle clockwise to decrease or counterclockwise to increase flow.

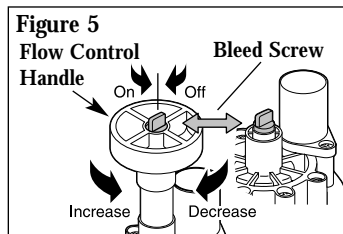
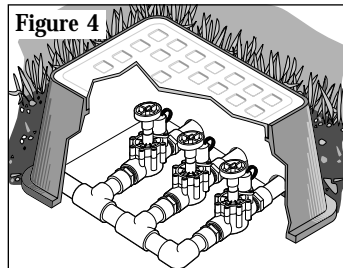
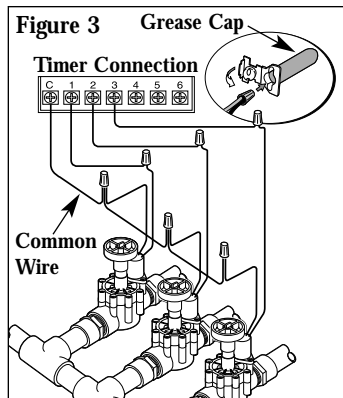

TORO

1" In-line Valve Models 53682 and 53683

- Installation Guide -

The Toro 1" in-line electric valves are designed for use in an automatic sprinkler system controlled by a 24 V a.c. timer. Both valve models feature 1" female-threaded inlet and outlet and manual bleed control which enables the valve to be operated without the use of the timer. In addition, the 53682 valve model features manual flow control adjustable to zero flow. The in-line valve is generally installed below grade, grouped with other valves in a manifold arrangement and housed in a protective valve box.

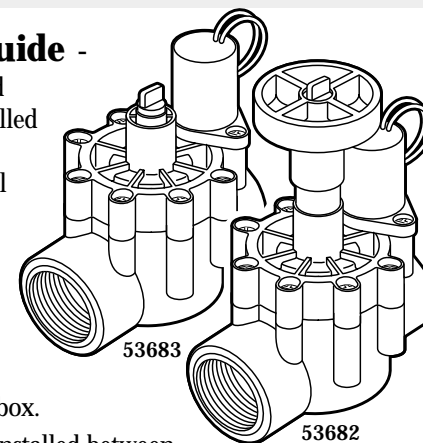

▲ Important: A backflow prevention device installed between the 1" in-line valve(s) and the water source point of connection is required in most areas to prevent back-siphoning of contaminants through the sprinkler system into the potable water supply. The Toro 1" Pressure Vacuum Breaker (PVB), model number 53300, is specifically designed for this purpose. Before connecting your irrigation system to the potable water supply, consult with your local water utility department for information regarding the type of backflow prevention device required for safe operation.

Valve Specifications:

Operating Pressure: 20–150 PSI

Flow Range: 5–45 GPM

Manual Flow Control: Adjustable to Zero Flow

Solenoid:

24 V a.c., 60 Hz (nominal)

19 V a.c., 60 Hz (minimum)

Inrush: 0.30 amps, 7.2 VA @ 24 V a.c., 60 Hz

Holding: 0.20 amps, 4.8 VA @ 24 V a.c., 60 Hz

Friction Loss:

GPM Flow	5	10	15	20	30	35	40	45
PSI Loss	3.5	4.0	3.0	3.3	6.2	7.0	8.7	10.5

Installation Procedure

Note: To ensure ease of installation and optimum valve performance, please read through the following instructions completely before starting the installation procedure.

Step 1- Route 1" schedule 40 PVC pipe from the backflow preventer or system shut-off device to the valve location. Flush the supply line thoroughly!

▲ Caution: Dirt, rocks and debris entering the valve can damage the valve and/or cause the valve to malfunction.

Step 2- The diagrams on the next page illustrate the two most commonly recommended methods of installing valves in a manifold arrangement. Referring to installation Method A or B, follow one of the installation procedures.

The Toro Promise — Limited One-Year Warranty

The Toro Company and its affiliate, Toro Warranty Company, pursuant to an agreement between them, jointly warrants, to the owner, each new piece of equipment against defects in material and workmanship for the period of one year from the date of purchase.

Neither Toro nor Toro Warranty Company is liable for failure of products not manufactured by them even though such products may be sold or used in conjunction with Toro products.

During such warranty period, we will repair or replace, at our option, any part found to be defective.

Return the defective part to the place of purchase.

Our liability is limited solely to the replacement or repair of defective parts. There are no other express warranties.

This warranty does not apply where equipment is used, or installation is performed, in any manner contrary to Toro's specifications and instructions, nor where equipment is altered or modified.

Neither Toro nor Toro Warranty Company is liable for indirect, incidental or consequential damages in connection with the use of equipment, including but not limited to: vegetation loss, the cost of substitute equipment or services required during periods of malfunction or resulting non-use, property damage or personal injury resulting from installer's negligence.

Some states do not allow the exclusion or limitation of incidental or consequential damages, so the above limitation or exclusion may not apply to you.

All implied warranties, including those of merchantability and fitness for use, are limited to the duration of this express warranty.

Some states do not allow limitations of how long an implied warranty lasts, so the above limitation may not apply to you.

This warranty gives you specific legal rights and you may have other rights which vary from state to state.

• **Installation Method A (Figure 1)**

Step 1- Apply three complete wraps of Teflon® tape to the slip/thread adapters.

▲ **Caution:** Use only Teflon tape on threaded connections. Pipe dope and other types of pipe thread sealants can damage plastic threads.

Step 2- Install a slip/thread adapter into each end of the valve and tighten securely.

Step 3- Cut a 4" length of 1" schedule 40 PVC pipe for each valve.

Step 4- Using PVC primer and cement, assemble the valve and PVC components as shown, aligning the tee fitting perpendicular to the valve. Repeat this procedure for each valve in the manifold.

Note: The last valve in the manifold can be connected with a 90° elbow instead of a tee. However, if future expansion of the sprinkler system is expected, use the tee fitting and a 4" section of 1" schedule 40 PVC pipe capped on the end. This enables the main line to be easily connected to additional downstream valves.

Step 5- Using 4" sections of 1" schedule 40 PVC pipe, connect the valve assemblies together to create the manifold, making sure the valves are aligned during assembly.

Step 6- Ensure the end of the supply line is dry and free of burrs. Cement the manifold to the main line.

Step 7- Allow the cemented connections to cure for a minimum of one hour (or per the cement manufacturer's directions) before applying water pressure. If no leaks occur after pressurization, begin connecting the sprinkler zone piping using 1" class 200 PVC pipe.

• **Installation Method B (Figure 2)**

Step 1- Apply three complete wraps of Teflon tape to both ends of a 4" long 1" PVC threaded pipe nipple and the slip/thread adapter.

▲ **Caution:** Use only Teflon tape on threaded connections. Pipe dope and other types of pipe thread sealants can damage plastic threads.

Step 2- Install the pipe nipple to the valve inlet and tee fitting and tighten securely, aligning the tee perpendicular to the valve. Install the slip/thread adapter into the valve outlet and tighten securely. Repeat this procedure for each valve in the manifold.

Note: The last valve in the manifold can be connected with a 90° elbow instead of a tee. However, if future expansion of the sprinkler system is expected, use the tee fitting and a 4" section of 1" schedule 40 PVC pipe capped on the end. This enables the main line to be easily connected to additional downstream valves.

Step 3- Using 4" sections of 1" schedule 40 PVC pipe, connect the valve assemblies together to create the manifold, making sure the valves are aligned during assembly.

Step 4- Ensure the end of the supply line is dry and free of burrs. Cement the manifold to the main line.

Step 5- Allow the cemented connections to cure for a minimum of one hour (or per the cement manufacturer's directions) before applying water pressure. If no leaks occur after pressurization, begin connecting the sprinkler zone piping using 1" class 200 PVC pipe.

Figure 1 - Installation Method A

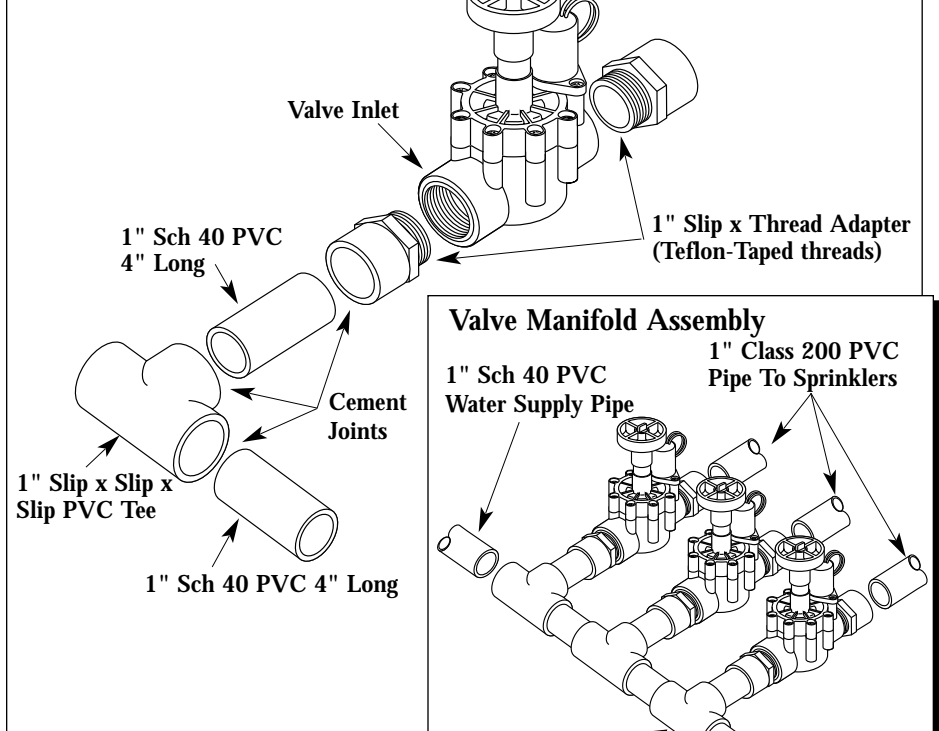

Figure 2 - Installation Method B

