

SAVIO Skimmerfilter™

Operating Manual & Specifications

Congratulations on purchasing the highest quality Skimmerfilter™ available. Familiarize yourself with the installation specifications and operating capabilities of your new Skimmerfilter™ prior to installation.

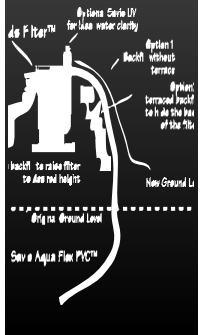
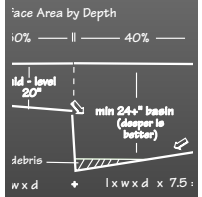
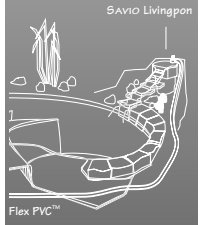
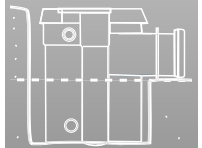
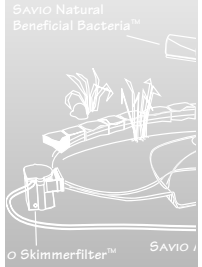

Operating Capacities

Skimmerfilter™ models 6025 & 8525 act as the sole source of filtration for ponds up to 1,000 gallons. On ponds over 1,000 gallons all Skimmerfilter™ models act as supplemental filtration to a SAVIO Livingponds™ filter. Models 60 & 85 incorporate biological filtration. All models include the capacity for either one or two integral Ultraviolet Clarifiers(UV). UVs create optimum water quality and can be purchased with the Skimmerfilter™ or added later. Consult the back of this booklet for pump flow rates to ensure efficient UV operation.



Important Safety Instructions



Locate a GFCI (ground fault current interrupter) protected power source nearby. Typically a 4 outlet, 15amp, 110v, grounded, single phase service is sufficient. Refer to your electrical equipment specifications or consult a qualified electrician to determine power demands for your system.

WARNINGS

- ✓ To prevent electrical shock disconnect all electrical devices including the UV filter before servicing Skimmerfilter™.
- ✓ Do not attempt to operate any electrical device with a damaged cord or plug.
- ✓ Do not attempt to remove any electrical device from the Skimmerfilter™ by pulling on its cord.
- ✓ Units with UV: UV light throws off radiation that can be harmful to skin and eyes. Always unplug the all power to the Skimmerfilter™ prior to servicing the UV unit. Never look at or touch a UV bulb during operation.

Placement

- 1) Place the Skimmerfilter™ opposite the waterfall or filter return in an easily accessible location.
- 2) Avoid placing rocks or plants in front of the Skimmerfilter™. Anything placed in front interferes with skimming action.
- 3) Waterfalls generally face the viewing area. Place the Skimmerfilter™ so it faces the waterfall. This hides the Skimmerfilter™ from view and allows easy access.
- 4) Positioning the Skimmerfilter™ on the down-wind side of the pond will aid in the effective collection of floating debris. This is less important than placing the Skimmerfilter opposite the waterfall but it is a significant design consideration.

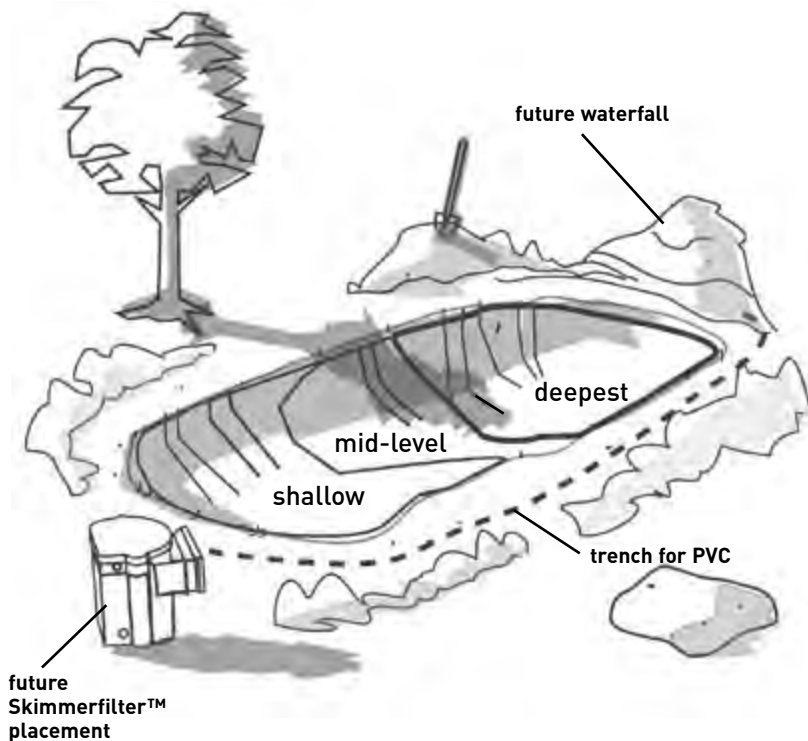

SAVIO Livingponds™ Design and Construction Guide

Consult your free guide to properly design and build your pond.

Components

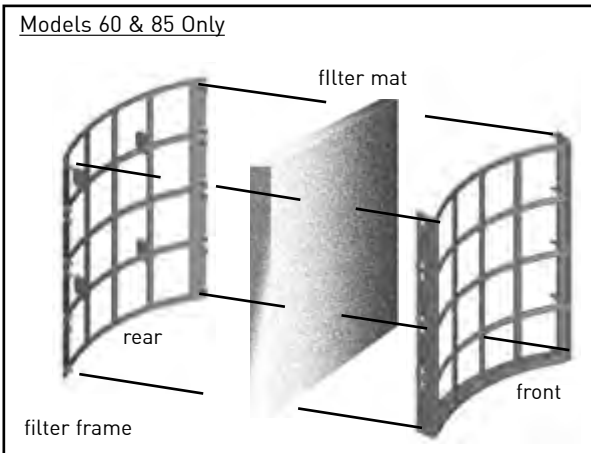
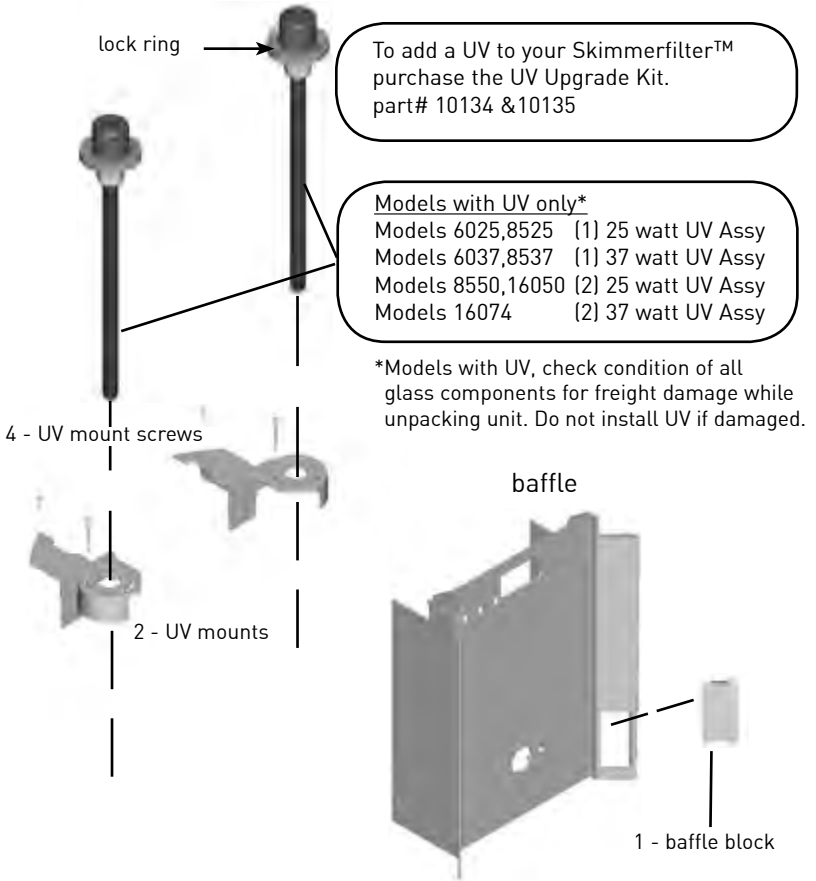

Components

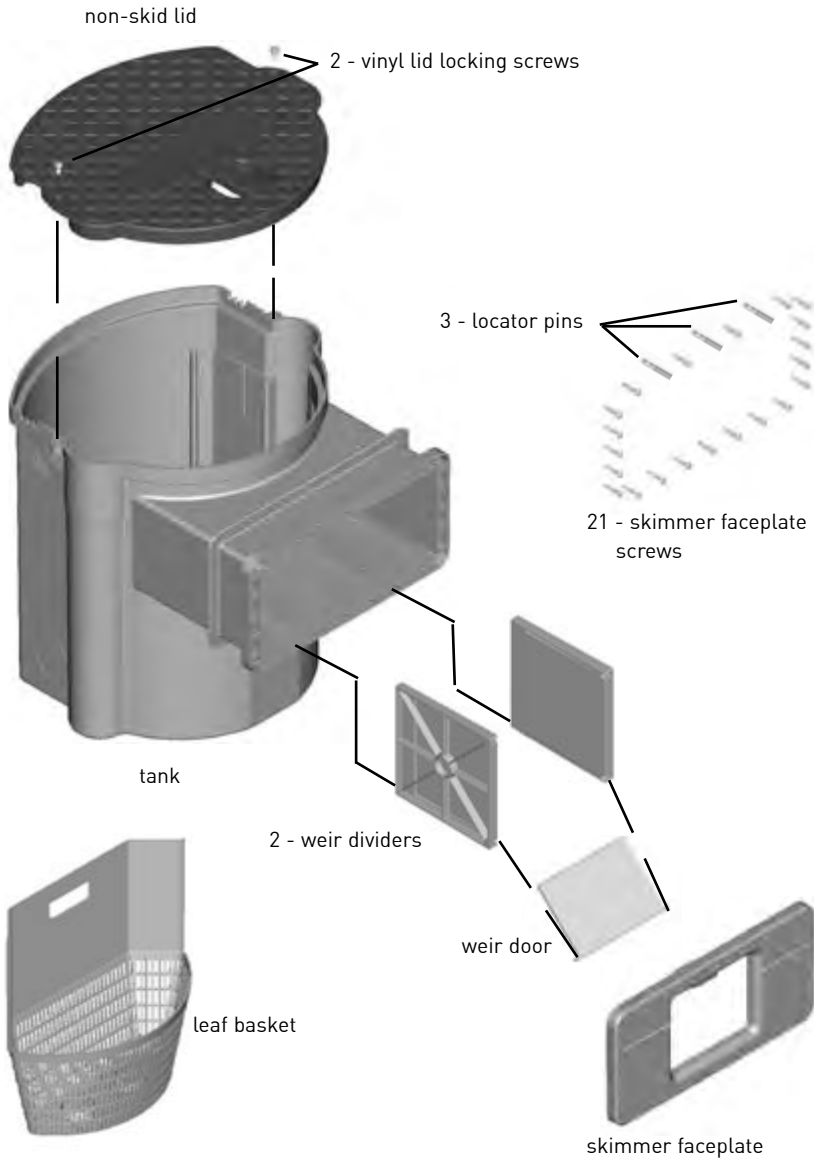

operating manual



pond construction guide



warranty card



Drill Hole for Pump

Use the side closest to your water return or waterfall. Cut a hole using a hole saw or jig saw using the guides shown on the side of the Skimmerfilter™.

Proper pipe size is determined by the flow of the pump and the length of the pipe run. This chart indicates the recommended inner diameter (I.D.) of pipe or tubing for the maximum gallons per hour (GPH) of the pump.

GPH	I.D.
1,000	1"
2,500	1½"
4,000	2"
7,000	3"

For 15' of horizontal pipe run add ½" I.D. to the pipe size. For 25' add 1" I.D.

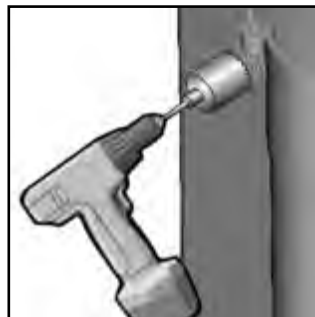

Excavate

- 1) Excavate 6" back from the coping shelf. Dig a round hole measuring 30" across, with a depth of 19" below the intended water line. Dig the front of the hole ¼" deeper than the back to compensate for future settling. When the Skimmerfilter™ is placed it will tilt slightly towards the pond. Do not dig too deeply or as soil settles it will become off level. Compact and level the bottom of the excavation.

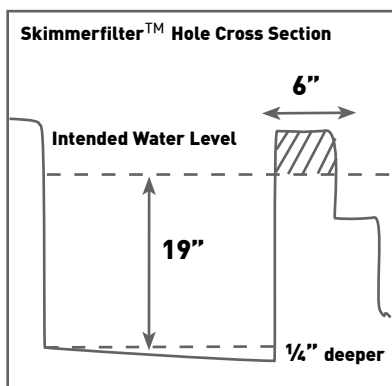
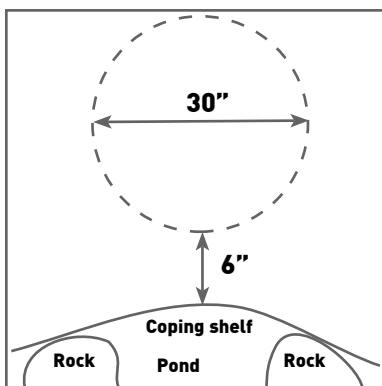

- 2) Dig a channel 7" below water line, measuring 24" wide, from the hole to the pond. The Skimmerfilter™ neck rests on this channel.

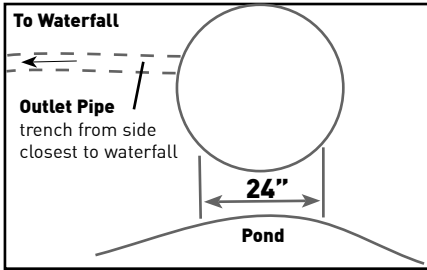

- 3) Dig a trench for the output pipe from the Skimmerfilter™ excavation. Extend this trench so that it connects to the waterfall filter.

Installation & Backfill

- 1) Place the Skimmerfilter™ in the hole. Verify:
 - a) There is least 3" of clearance all of the way around the unit.
 - b) The unit is level front to back and side to side. Front edge is $\frac{1}{4}$ " lower than the back edge to compensate for settling.
 - c) The skimmer face is flush with the back wall of the coping shelf (see Top View).
 - d) Skimmerfilter™ is positioned so the bottom is 19" below the intended water level. The bottom of the neck is 7" below water level.

Top View

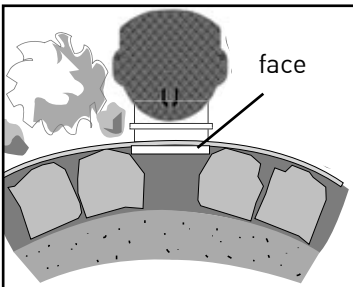

Side View

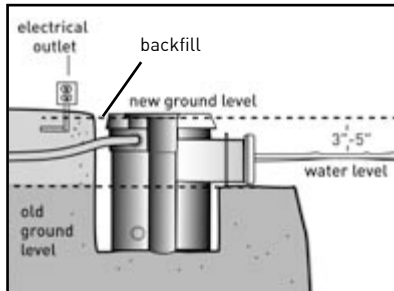

water level mark

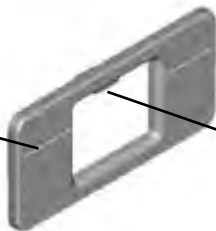

tab is located at top of faceplate

Installation & Backfill

- 2) Place the lid on top of the Skimmerfilter™ and backfill around the unit. Use moist sand or pea gravel for backfilling or, if unavailable, use gravel

and loose soil (free from clumps). Every two or three inches hand-pack backfill. Do not over compact. Lightly moisten backfill to aid in settling.

Connect Pump

Submersible Pump

The Skimmerfilter™ tank protects and hides the submersible pump. The leaf basket protects the pump(s) from large debris and reduces clogging. Use a solids handling pump for water gardening applications. Remove filter media if pump flow rate exceeds 3000 gph.

- 1) Slide the PVC pipe from the pump through the outlet pipe hole.
- 2) Use a quick disconnect coupling for easy pump removal.

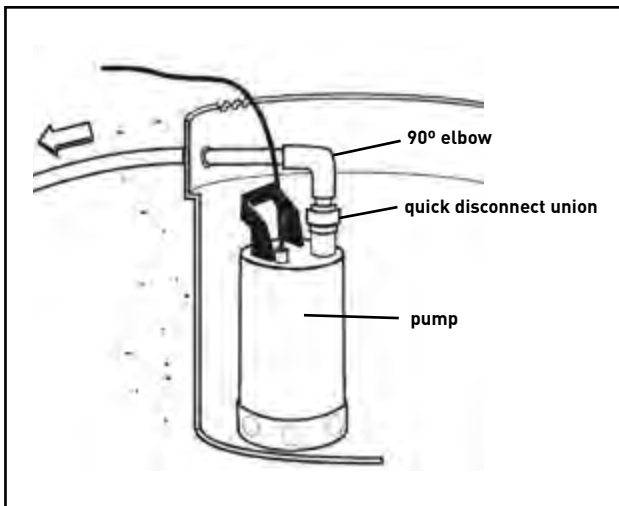

External Pump

To install an external pump using the SAVIO Skimmerfilter™ purchase the external pump adapter kit (part no. 10132) and follow the instructions.

Optional Mid-Water Intake

A mid-water intake helps prevent pump burnout if the water level falls below the level of the weir. In winter months, when ice forms on the pond, the Skimmerfilter™ door can be closed and water can be drawn from below the surface of the pond. To install a mid-water intake for the SAVIO Skimmerfilter™ purchase the mid-water intake kit (part no. 10133).

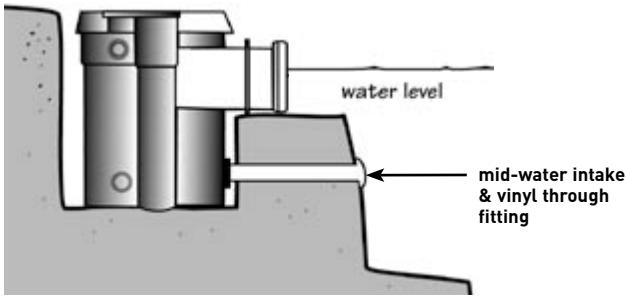

Leaf Basket

The Skimmerfilter™ basket is constructed of durable injection molded material. The weave of the basket is designed to catch large debris. Fine debris will pass through the weave and be captured by the filter mat or processed through a solids handling pump and collected in the Livingponds™ filter.



Attach Weir

- 1) Insert weir dividers in the appropriate slots for the model purchased.
 - Model 60 use innermost tracks
 - Model 85 use middle tracks
 - Model 160 use outermost tracks

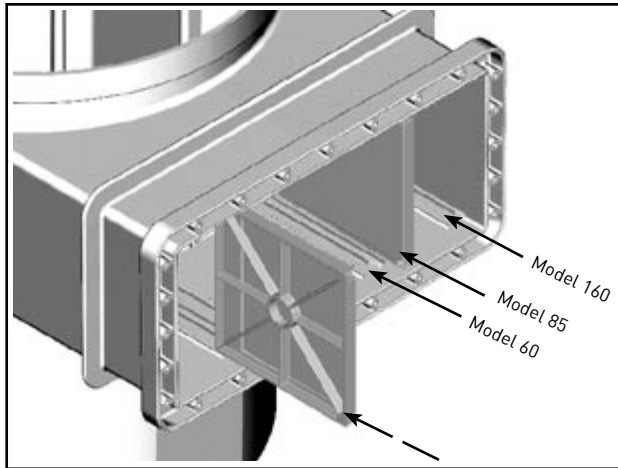

Weir dividers shown inserted for model 85.

- 2) Push weir door hinge tabs into notches on weir dividers as shown. Lay the door horizontal in the Skimmerfilter™ neck.

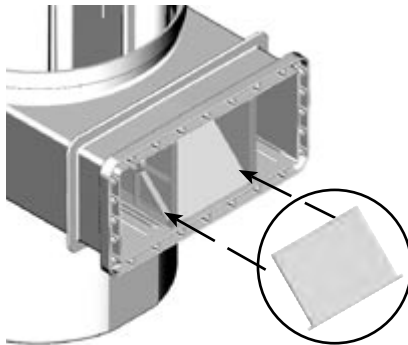

Attach Liner

- 1) Position the pond liner over the mouth of the Skimmerfilter™ and hold it in place. Clean and flatten the liner free of wrinkles and folds along the front of the Skimmerfilter™ face.
- 2) Insert locator pins through liner into the holes indicated below.

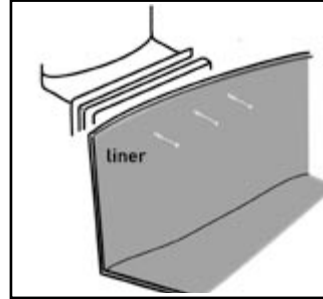
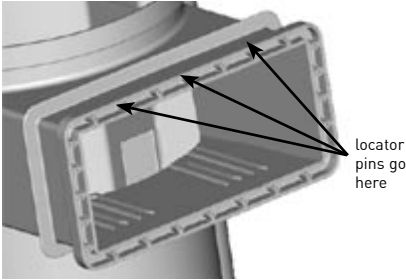

- 3) Make a 3" incision through the liner centered and 3/4" below the top of the skimmer opening.

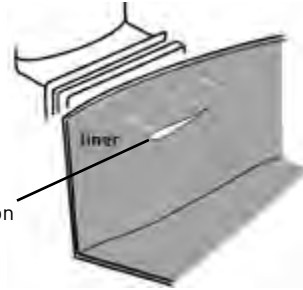

- 4) Slide the faceplate over the locator pins to align the screw holes.

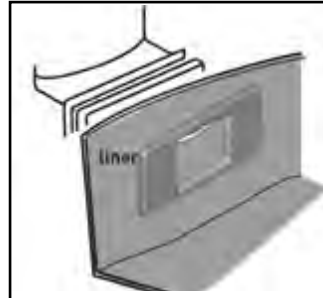

- 5) Use a #3 phillips head screwdriver to install corner screws half way into all 4 corners. Place the rest of the screws halfway. Alternate tightening the screws from top to bottom and side to side until the screw heads are flush with faceplate. This creates a water tight seal.
- 6) After the faceplate is properly tightened down, use a knife to trim the liner inside the skimmer mouth.

UV Assembly

For Skimmerfilters™ with one or more UVs:

- 1) Follow the instructions provided in the UV kit.
- 2) Remove the lid.
- 3) UVs are fragile. Avoid fingerprints on bulb which shorten its life span.
- 4) Place the UV assembly in UV mount(s). Insert the lock ring tabs in slots and rotate 1/4 turn to secure.
- 5) Replace lid.
- 6) Connect UV to power source.
- 7) Use a baffle block to close off flow

water flow to the unused UV compartment

For ponds less than 3000 gallons incorporating one UV. For ponds with over 3000 gallons do not use baffle block on either compartment.

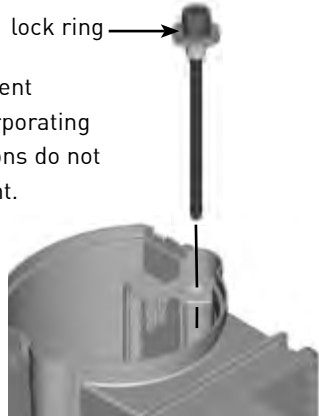

Flow Rates

Model#	25 watt 37 watt		GPH (min-max)
	UV	UV	
6025	1		500 - 2500
6037		1	500 - 4000
8525	1		1200 - 2500
8537		1	1200 - 4000
8550	2		1200 - 5000
16050	2		2500 - 5000
16074		2	2500 - 8000

The pump needs to flow the total volume of pond water past the UV no faster than every 30 minutes, and no slower than every two hours. The chart at right gives recommended pump flow rates for each model. If water flows past the UV lamp too fast the UV will not be able to eliminate algae efficiently. If water flows too slow the UV will not keep up with algae growth in the pond. Use one UV for ponds up to 5000 gallons. Use two UVs for larger ponds.

Note: When introducing beneficial bacteria into a pond. Turn off the UV unit for 24 hours to allow bacteria to settle.

Water Level

The water level mark on the Skimmerfilter™ faceplate represents optimum water level for proper Skimmerfilter™ operation when the unit is running.

Operating tolerances allow water levels to run 3/4" above or below this mark. For best performance use a SAVIO Automated Water Level Sensor™ to keep water level at desired height automatically.

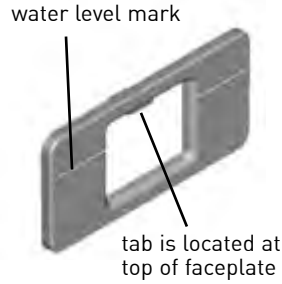

Maintenance

Under normal operating conditions this Skimmerfilter™ will provide years of trouble-free use. Here are a few items which will require periodic maintenance:

Short Term Maintenance

- 1) Check and remove debris captured in the leaf basket every week or as needed. The frequency required will vary seasonally, with cleaning required more often in the fall than at other times.
- 2) Check and clean the filter mat as needed using water from the pond. Clean the filter when it looks dirty or before there is a noticeable decrease in the flow of water to the pump chamber.

Long Term Maintenance (every 18 months)

- 1) Replace UV bulbs every 18 months for optimal water clarity.
- 2) Quartz sleeves protecting the UV clarifiers can be soaked in an acid solution annually or as needed if mineral buildup occurs. Use caution when removing or replacing bulbs.

One-Click Locking Weir™

Using the Skimmerfilter's™ patented One-Click Locking Weir™ makes cleaning a snap.

- 1) Turn off electrical components.
- 2) Remove lid.
- 3) Reach into tank and, while pressing the weir lock lever, upward push weir door forward unit you feel it lock upright into place.
- 4) To release, reach into tank and press the release lever upward.



Equipment Winterization

Prepare for winterization in mid-to-late November, or when ice persistently develops on the pond. Keep equipment winterized until late February or early March when the water temperature rises to a 40° or higher consistently.

If the pond is to be shut down in Winter:

- 1) Disconnect UV clarifiers and store indoors.
- 2) Close and lock One-Click Locking Weir.™
- 3) While monitoring operation allow the pump to drain a majority of water from inside the Skimmerfilter.™ When the Skimmerfilter™ has been emptied turn off the pump.
- 4) Disconnect submersible pump, clean and store in a dry place.
- 5) Drain any plumbing lines not buried below frost line (18"-24" in agricultural zones 4-6).
- 6) Use plumber's heat tape on pipes and shut off valves. Insulate the pump house and exterior pumps and valves.
- 7) Remove and thoroughly clean filter mat.

Replacement Parts

<u>Part #</u>	<u>Part Description</u>	<u>Part #</u>	<u>Part Description</u>
10101	tank	10117	filter frame rear
10103	leaf basket	10118	filter frame front
10104	baffle	10119	weir divider
10105	UV mount L	10120	baffle block
10106	UV mount R	10127	faceplate screw
10107	faceplate 16"	10128	UV mount screw front
10108	faceplate 8.5"	10129	UV mount screw rear
10109	faceplate 6"	10130	vinyl lid locking nut
10110	weir door 16"	10131	brass insert for lid lock
10111	weir door 8.5"	10132	external pump adapter kit
10112	weir door 6"	10133	mid-water intake adapter kit
10113	seal 16"	10134	UV upgrade kit (25W)
10114	seal 8.5"	10135	UV upgrade kit (37W)
10115	seal 6"	10136	lid (turf green)
10116	replacement filter media	10137	lid (iron black)

Skimmerfilter™ lids are available in Turf Green or Iron Black.

Troubleshooting

Faults	Possible Causes	Remedies
<p>Pump Chamber runs dry during operation.</p>	<p>Low water level in pond.</p> <p>Weir door closed/stuck/obstructed</p> <p>Weir not large enough for pump flow.</p>	<p>Add water to pond. Water level should be between 3/4" above or below optimum water mark on faceplate.</p> <p>Ensure free movement of weir door/ remove obstruction.</p> <p>Reduce pump flow.</p> <p>Install smaller pump.</p> <p>Install larger weir assembly.</p>
<p>Water leak around faceplate.</p>	<p>Faceplate screws not tight.</p> <p>Faceplate not sealed properly.</p>	<p>Use #3 phillips screwdriver to hand tighten screws snugly.</p> <p>Remove weir face, clean liner of mud or gravel, smooth wrinkles. Reinstall.</p>
<p>Filter pad requires frequent cleaning.</p>	<p>Pump flow rate too high.</p> <p>Heavy waste load in pond due to fish, or plant debris.</p>	<p>Adjust pump flow rate to 4,000 gallons or less.</p> <p>Remove filter pad. Add a SAVIO Livingponds™ filter.</p>
<p>No debris collected by Skimmerfilter™</p>	<p>Weir door closed/stuck/obstructed</p> <p>Pump is not functioning.</p>	<p>Ensure free movement of weir door/ remove obstruction.</p> <p>Check operation of the pump and pump screen (if equipped).</p>



Customer Service Information



SAVIO Engineering, Inc.

<http://www.savio.cc>

Email: support@savio.cc

(505) 424-9492

8 Water Garden Way

Santa Fe, NM 87508 USA

Warranty (Send in your warranty card)

To activate your warranty, and to receive free Water Gardening Newsletters, send in the enclosed warranty card. SAVIO Engineering, Inc. provides a manufacturer's limited warranty of 5 years from original purchase date. Warranty is non-transferable. Within the warranty period SAVIO will repair materials with manufacturing deficiencies at their discretion, free of charge. This warranty does not cover any faults caused by improper use of the device or as a result of wear and tear. SAVIO Engineering, Inc. does not assume liability for consequential damage caused by the failure of the Skimmerfilter™. Warranty is void if the product is used as part of a rental program or not in accordance with these instructions. For warranty claims, please contact customer service. Transport the device in the original packaging to avoid damage during transport. SAVIO is not responsible for damage resulting from shipping.

SAVIO water gardening products for healthy, clean Livingponds™

SAVIO Skimmerfilters™

SAVIO Springflo Bio Filter Media™

SAVIO Automated Water Level Sensor™

SAVIO Livingponds Filters™

SAVIO Natural Healthy Water Conditioner™

SAVIO Natural Beneficial Bacteria™

SAVIO Parasite Prevention™

SAVIO Water Master Pumps™

SAVIO Mud Sweeper Vacuum™

SAVIO Natural Barley Extract™

SAVIO Aqua Flex PVC™

SAVIO Ich Prevention™

